

Forged Wire Rope Clamps

Look for the Yellow-U-Bolt
 your assurance of
 SL Clamps.

SEALINKERS CLAMPS

- Each clamps has a product Identification Code for Material traceability, the name SEALINKERS or "SL", and a size forged into it.
- Entire Clamps are galvanized / Powder Coated to resist corrosive and rusting action.
- Only Genuine SL Clamps have a Yellow colour for instant recognition.
- All Clamps have rolled threads and extra heavy nuts.



SL-450

SL Clamps, all sizes 1/4" and larger, meet federal Specification

Rope Size		Dimensions (mm)								Min No. of Clamps	Amt. of Rope to Turn Back in (cm)
(in.)	(mm)	A	B	C	D	E	F	G	H		
3/8	9-10	11.2	38.1	19.1	25.4	23.1	19.2	41.4	49.3	2	16.5
1/2	13	12.7	47.8	25.4	30.2	28.7	22.4	48.5	58.0	3	29.2
5/8	16	14.2	60.5	31.8	33.3	34.0	23.9	52.5	63.5	3	30.5
3/4	18-20	15.8	70.0	36.6	38.1	35.8	26.9	57.0	72.0	4	46
7/8	22	19.1	79.5	41.2	44.5	40.4	31.8	62.0	80.5	4	48
1	24-26	19.1	89.0	46.0	47.8	45.2	31.8	67.0	88.0	5	66
1 1/8	28-30	19.1	98.5	51.0	51.0	48.5	31.8	71.5	91.0	6	86
1 1/4	32-34	22.4	108	54.0	58.5	55.5	36.6	79.5	105	7	112
1 3/8	36	22.4	118	58.5	60.5	58.5	36.6	79.5	106	7	112
1 1/2	38-40	22.4	125	60.5	65.5	62.0	36.6	86.5	113	8	137
1 3/4	44-46	28.7	146	70.0	77.5	74.5	46.0	97.0	134	8	155
2	48-52	31.8	164	76.0	86.0	83.5	51.0	113	149	8	180

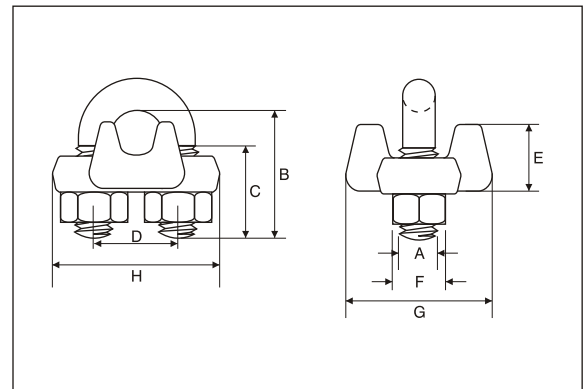

1. Refer to above table in following these instructions. Turn back specified amount of rope from thimble or loop. Apply first clip one base width from dead end of rope. Apply U-Bolt over dead end of wire rope - live end rests in saddle (Never Saddle a dead horse!). Tighten nuts evenly, alternate from one nut to the other until reaching the recommended torque.

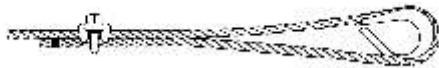

2. When two clips are required, apply the second clip as near the loop or thimble as possible. Tighten nuts evenly, alternating until reaching the recommended torque. When more than two clips are required, apply the second clip as near the loop or thimble as possible, turn nuts on second clip firmly, but do not tighten. Proceed to Step 3.



3. When three or more clips are required space additional clips equally between first two - take up rope slack-tighten nuts on each U-Bolt evenly, alternating from one nut to the other until reaching recommended torque.

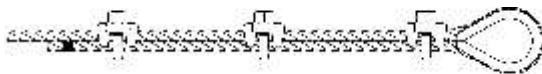

4. WIRE ROPE SPLICING PROCEDURES :

The Preferred method of splicing two wire ropes together is to use interlocking turnback eyes with thimbles, using the recommended number of clips on each eye (See Figure 1). An alternate method is to use twice the number of clips as used for a turnback termination. The rope ends are



Figure 1

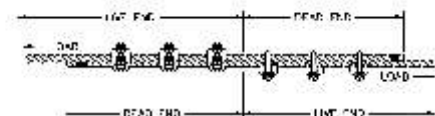

Figure 2

placed parallel to each other, overlapping by twice the turnback amount shown in the application instruction. The minimum number of clips should be installed on each dead end (See Figure 2). Spacing, installation torque, and other instructions still apply.

5. IMPORTANT

Apply first load to test the assembly. This load should be of equal or greater weight than loads expected in use. Next, Check and retighten nuts to recommended torque.

In accordance with good rigging and maintenance practices, the wire rope end termination should be inspected periodically for wear, abuse, and general adequacy.

Specifications given are indicative and are subject to change.